



ART 511U-513U

DRAWERS: BLUM TANDEMBOX, GRASS NOVA PRO,
GRASS DWD XP, HETTICH ARCTECH

REV 00.2026

FOIST00175

SIGE S.P.A.
60020 POLVERIGI (AN) ITALY
TEL +39 071 90 90 000 R.A. - FAX +39 071 90 90 804
WWW.SIGE-SPA.IT INFO@SIGE-SPA.IT

PRODOTTO ED ASSEMBLATO IN ITALIA / MADE AND ASSEMBLED IN ITALY / FABRIQUÉ ET ASSEMBLÉ EN ITALIE / HECHO Y MONTADO EN ITALIA

CARATTERISTICHE • FEATURES • CARACTÉRISTIQUES • CARACTERÍSTICAS

Portabiancheria su sponda con sacchi in tessuto. Compatibile con sponde Blum Tandembox, Hettich Arcitech, Grass DWDXP e Grass Nova Pro.
Laundry bins installed on the drawer with fabric bags. Suitable for Blum Tandembox, Hettich Arcitech, Grass DWDXP e Grass Nova Pro.
Bacs à linge installés sur le tiroir avec sacs en tissu. Compatibles avec les tiroirs Blum Tandembox, Hettich Arcitech, Grass DWDXP et Grass Nova Pro.
Cubos de ropa instalados en el cajón con bolsas de tela. Adaptable a cajones Blum Tandembox, Hettich Arcitech, Grass DWDXP y Grass Nova Pro.

MINUTERIA INTERNA • FITTINGS • FERRURE • FERRETERIA

N°6 4,2x6,5 Vite autofilettante TC a croce / Self tapping TC screw / Vis autotaraudeuse TC / Tornillo autorroscante TC

N°8 3,9x13 Vite autofilettante TC a croce / Self tapping TC screw / Vis autotaraudeuse TC / Tornillo autorroscante TC

N°4 M5x8 mm Viti / Screws / Vis / Tornillos

N°4 M5x13 Vite speciale con impronta esagonale / Special hex key screw /

Vis clé hexagonale spéciale / Tornillo de llave hexagonal especial

N°1 Chiave a brugola / Allen key / clé Allen / llave Allen

COMPONENTI • PARTS • COMPOSANTS • COMPONENTES

A. N°1 Telaio / Frame / Châssis / Marco

B. N°2 Carter regolabile / Adjustable carter / Carters adaptable / Carter ajustable

C. N°2 Squadretti stabilizzatori antenna / Door stabilizing elements /

Elements de stabilisation de la porte / Elementos para la estabilización de la puert

D. N°2 Cover / Cover / Cover / Cover

E. Sacchi portabiancheria / Laundry bags / sacs à linge / bolsos de lavandería

F. Velcro / Velcro / Velcro / Velcro

UTENSILERIA • TOOLS • OUTILS • INSTRUMENTOS



MANUTENZIONE • MAINTENANCE • ENTRETIEN • MANTENIMIENTO

Pulire con un panno morbido ed asciutto. Evitare l'uso di solventi e/o abrasivi. Lavare sacchetto a 30°.

Clean with a soft, dry cloth. Avoid using solvents or abrasive. Wash bag at 30°.

Nettoyez avec un chiffon sec et doux. N'utilisez pas aucun solvant ou produit abrasif. Laver le sac à 30°.

Limpiar con paño suave y seco. Evitar el uso de solventes y/o abrasivos. Bolsas de lavado a 30°.

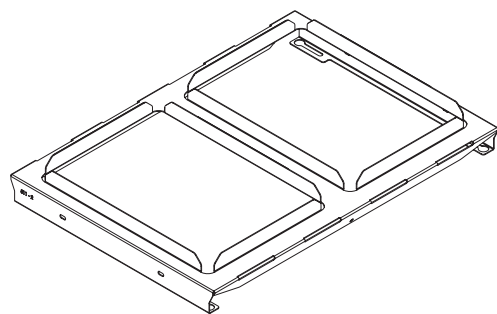
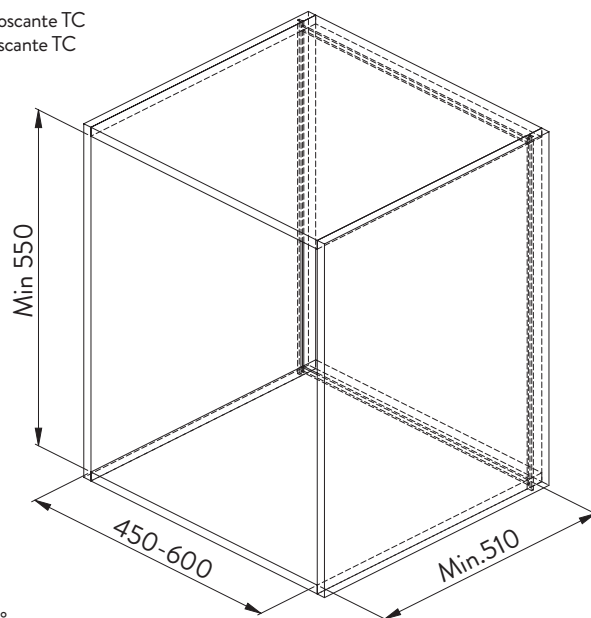

A

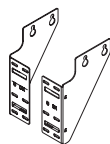

C

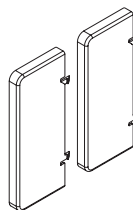

D

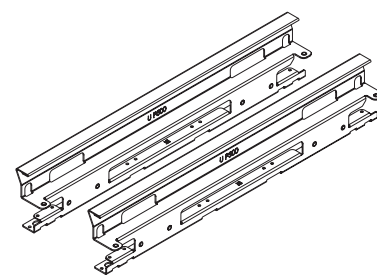

B

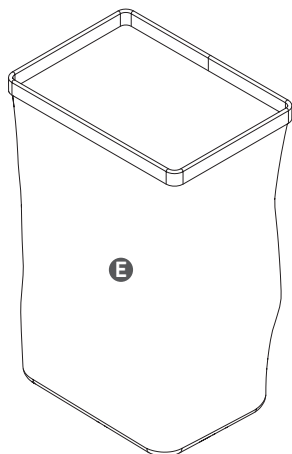

E



F

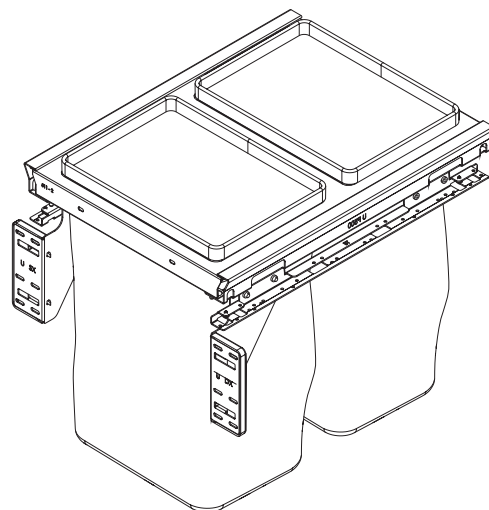

1

Montare le guide cassetto all'altezza indicata.
Fix the drawer slides at the suggested height.
Installer les coulisses des tiroirs à la hauteur recommandée.
Instalar las guías del cajón a la altura indicada.

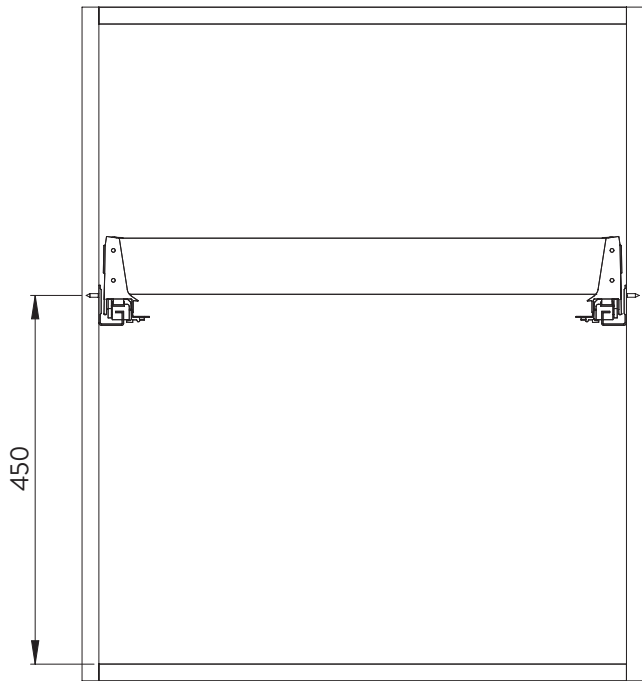
**2**

Installare lo schienale (non fornito) sulle sponde cassetto.
Assemble the back of the drawer (not supplied) on the drawer system.
Installer le dossier (non fourni) sur les côtés du tiroir.
Instalar el respaldo (no incluido) en los lados del cajón.

ES. Cassetto Blum tandembox.
E.G. Blum tandembox drawer.

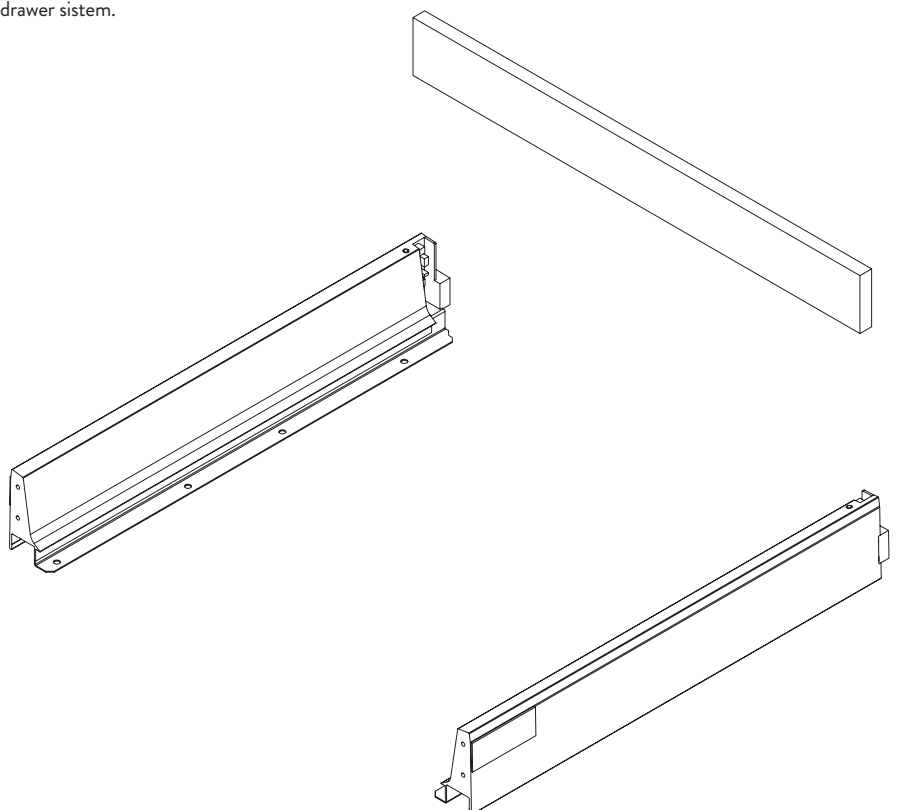

3

Assemblare il telaio A con i carter B, come mostrato.

Assemble the frame A with the carters B, as shown.

Assembler le châssis A avec les carter B, comme illustré.

Ensamblar el marco A con los cárter B, como se muestra.

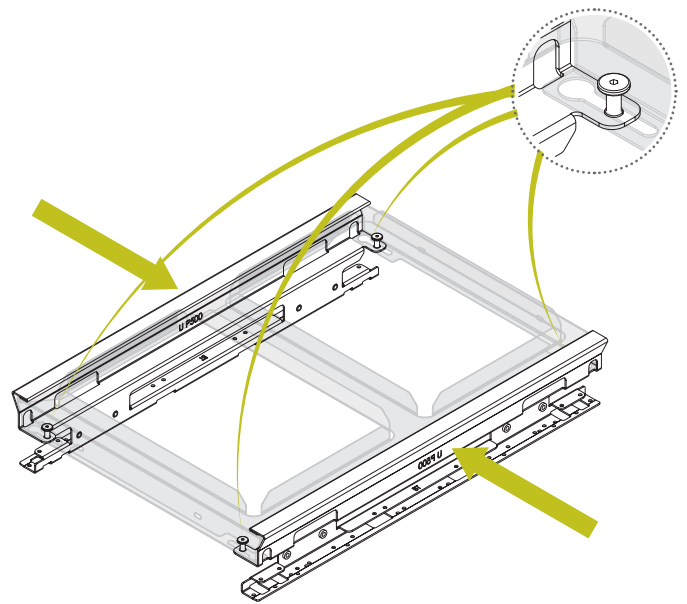
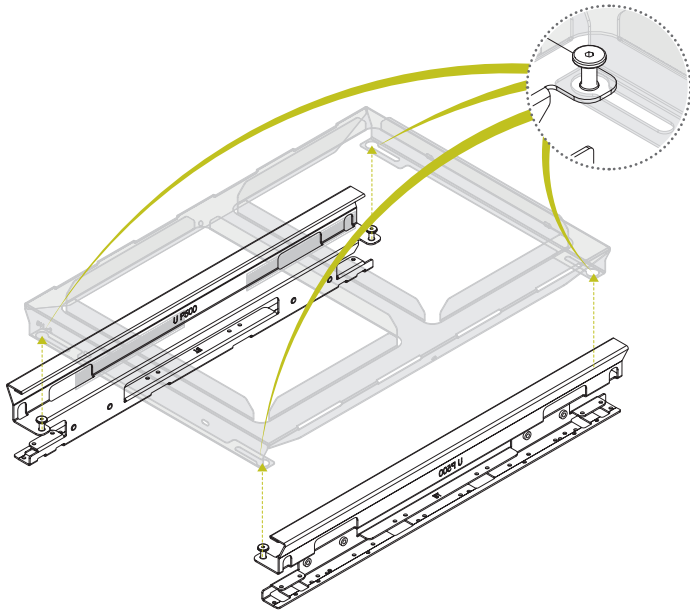

4

Ruotare sul lato inferiore ed assemblare la carcassa con le sponde del cassetto, come mostrato.

*Attenzione: montare correttamente la carcassa come mostrato nei riquadri a seconda del tipo di cassetto utilizzato.

Turn upside down and assemble the chassis with the drawer sides, as shown.

* Attention: mount the chassis in the correct way, as shown in the boxes, according to the type of drawer used.

Renverser et assemblez le carcasse avec les côtés du tiroir, comme illustré.

* Attention: monter le carcasse dans le bon sens, comme indiqué dans les cartons, en fonction du tiroir utilisé.

Girar en la parte inferior, y ensamblar el chasis con los lados del cajón, como se muestra.

* Atención: montar el chasis correctamente, como se muestra en los recuadros, según el tipo de cajón utilizado.

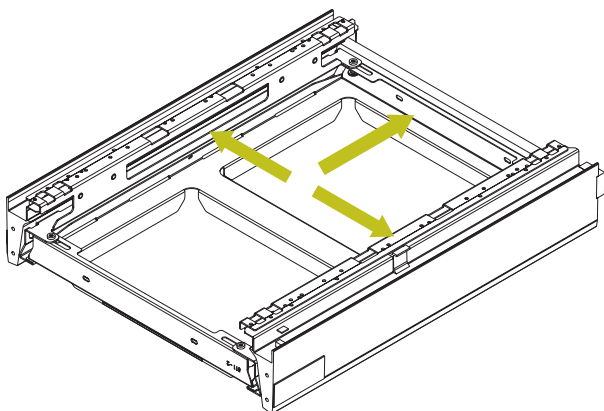
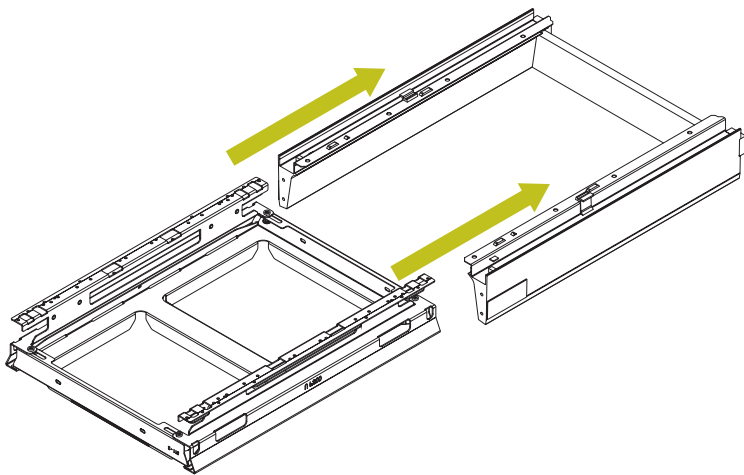

BLUM TANDEMBOX

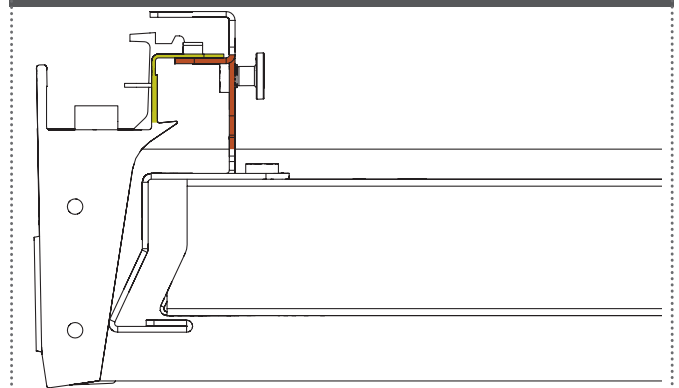

GRASS NOVA PRO, GRASS DWD XP, HETTICH ARCITECH

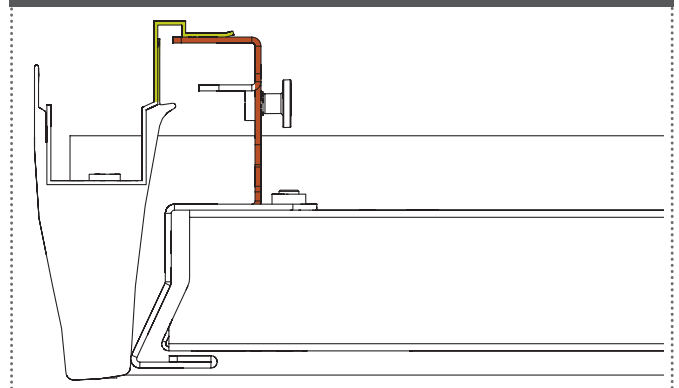

N°6 4,2x6,5



ES. Cassetto Blum tandembox.
E.G. Blum tandembox drawer.



5

Fissare la carcassa alle sponde cassetto utilizzando le sei viti 4.2x6.5, quindi ruotare sul lato superiore.
Fix the chassis in to the drawer using the six 4.2x6.5 screws, then rotate on the upside.
Fixer le carcasse dans le tiroir à l'aide des six vis 4,2x6,5, puis tourner à l'envers.
Fijar el chasis en el cajón con los seis tornillos 4.2x6.5, y girar en la parte superior.

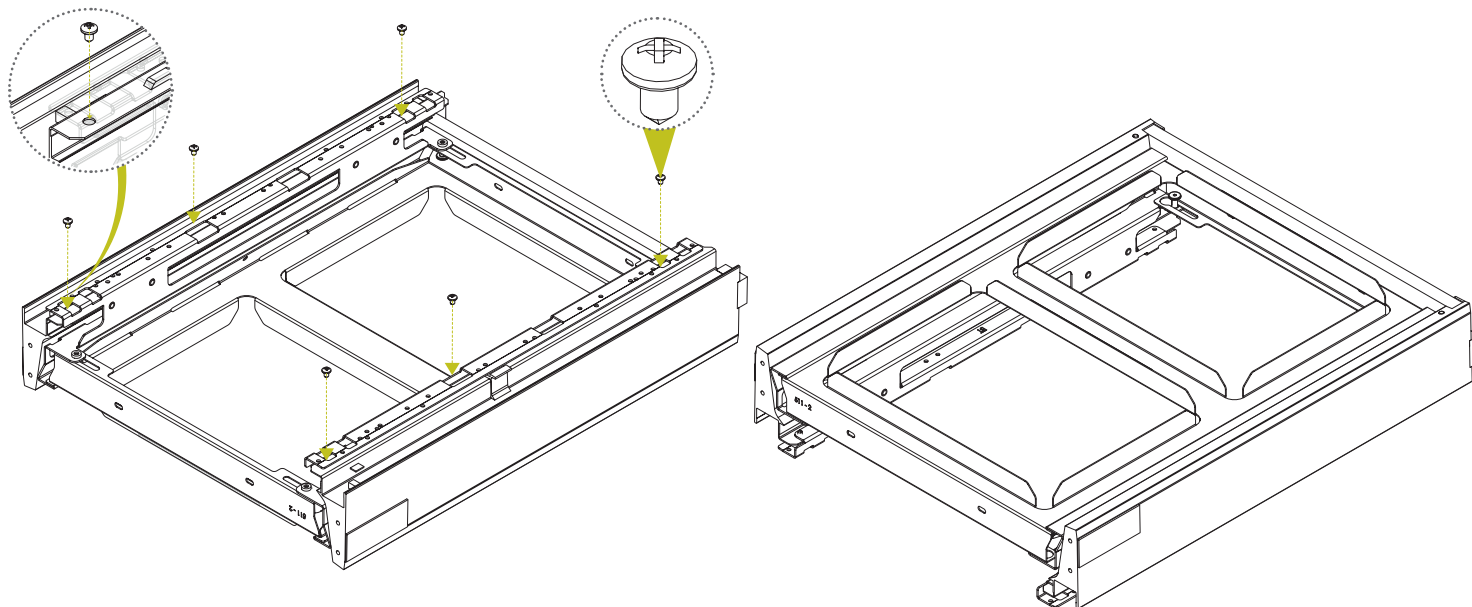

ES. Cassetto Blum tandembox.
E.G. Blum tandembox drawer.



6

Montare il cassetto sulle guide.
Mount the drawer on the slides.
Monter le tiroir sur les coulisses.
Montar el cajón en las guías.

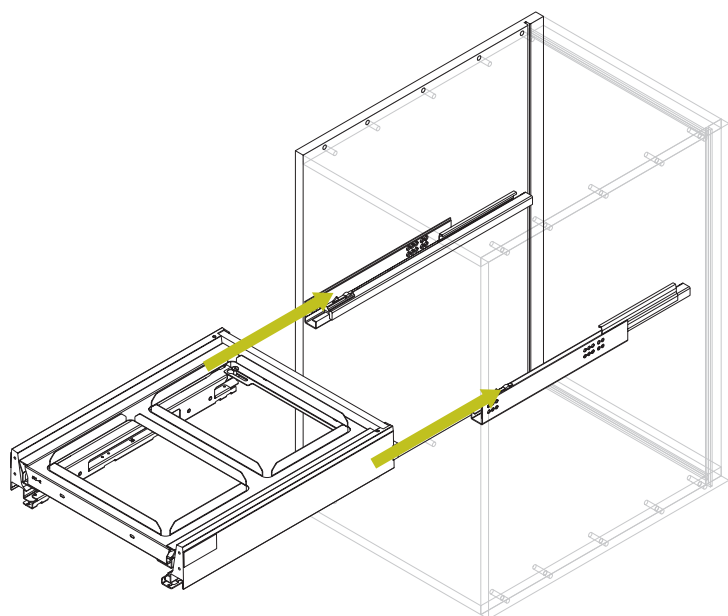

7

Montare l'antina sul cassetto.
Mount the door on the drawer.
Monter la porte sur le tiroir.
Montar la puerta en el cajón.

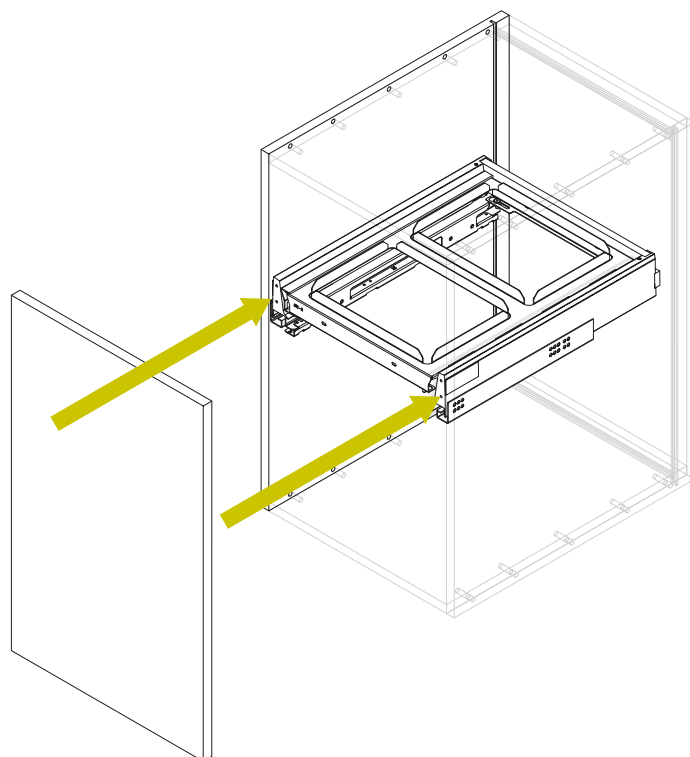

8

Regolare l'antina tramite le regolazioni del sistema cassetto.
Adjust the door through drawers adjustment system.
Ajuster la porte grâce au système de réglage des tiroirs.
Ajustar la puerta mediante el sistema de regulación de los cajones.

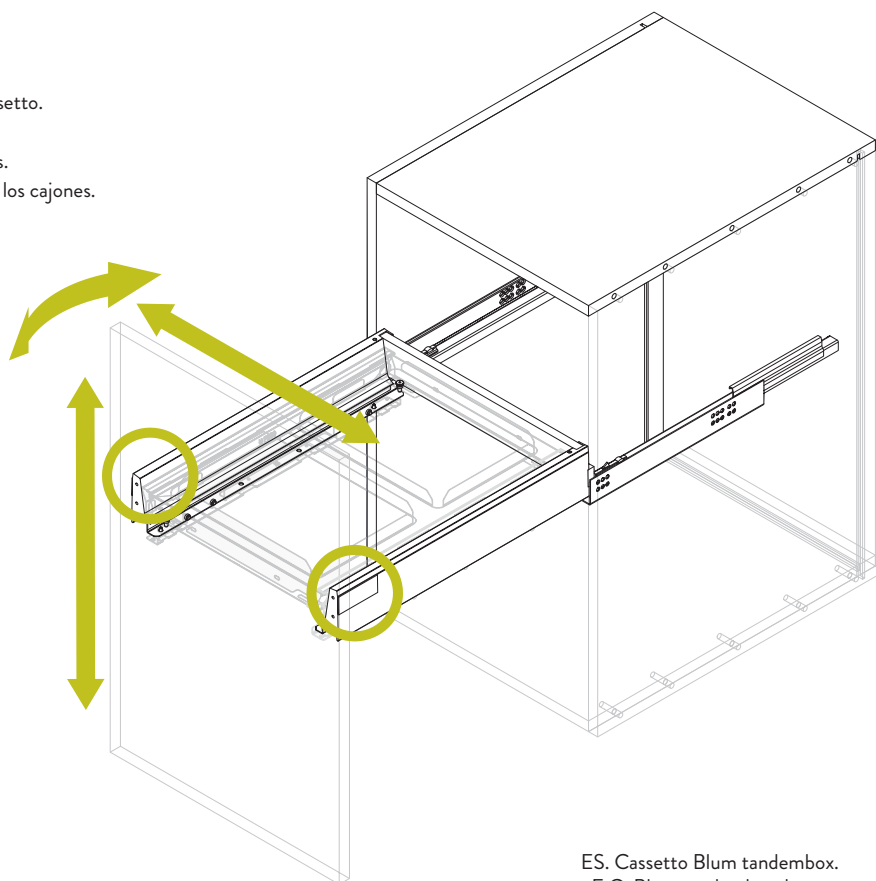

ES. Cassetto Blum tandembox.
E.G. Blum tandembox drawer.



9

Fissare il telaio A ai carter B serrando da sotto le quattro viti speciali M5x13 con la chiave a brugola.
Fix the frame A to the carters B by tightening the four M5x13 special screws from below with the allen key.
Fixer le chassis A aux carters B en serrant en dessous les quatre vis spéciales M5x13 avec la clé Allen.
Fijar el marco A a los cárter B apretando desde abajo los cuatro tornillos especiales M5x13 con la llave Allen.

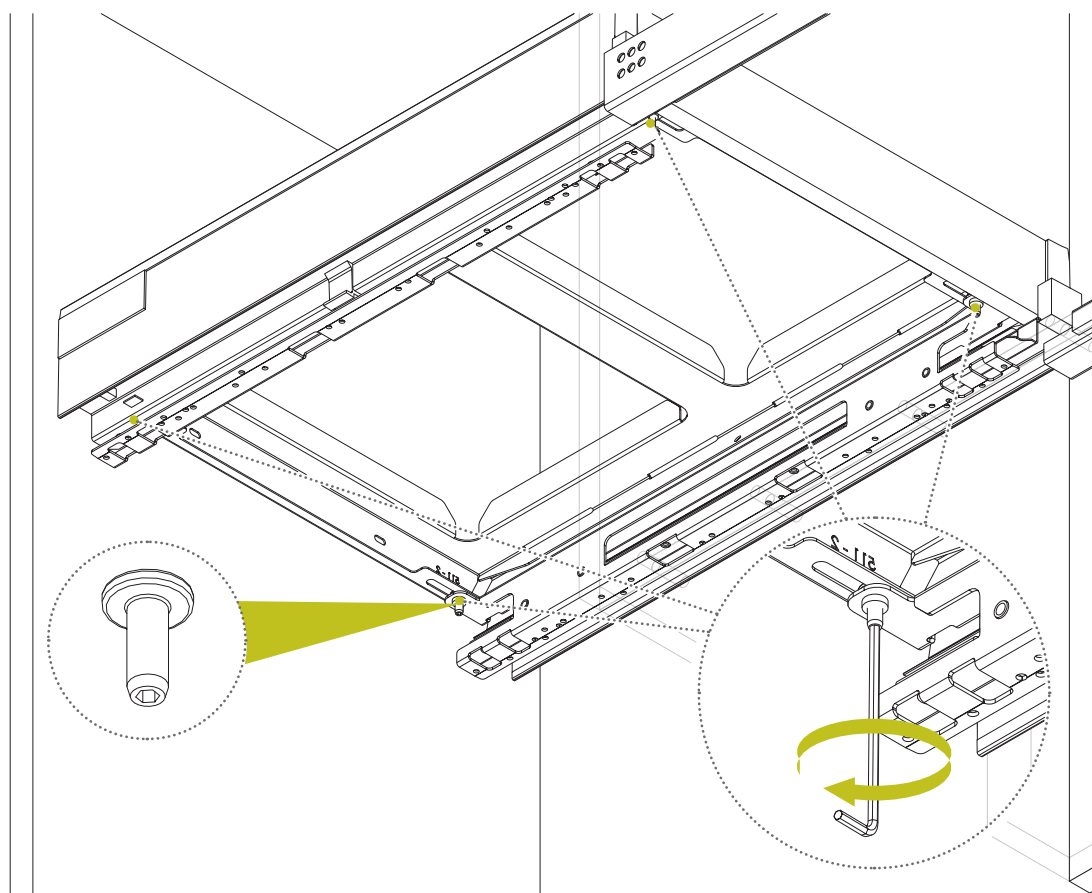

N°4 M5x8



10

Premontare le quattro viti M5x8 sulla parte anteriore del carter B. Appendere gli squadretti stabilizzatori anta C sulle viti premontate.

Pre-mount four M5x8 screws on the front side of the carter B. Hang the door stabilizing elements C on the pre-mounted screws.

Prémontez les quatre vis M5x8 sur le front du carter B. Accrochez les éléments de stabilisation de la porte C sur les vis prémontées.

Montar previamente los cuatro tornillos M5x8 en la parte frontal del cárter B. Colgar los elementos para la estabilización de la puerta C en los tornillos premontados.

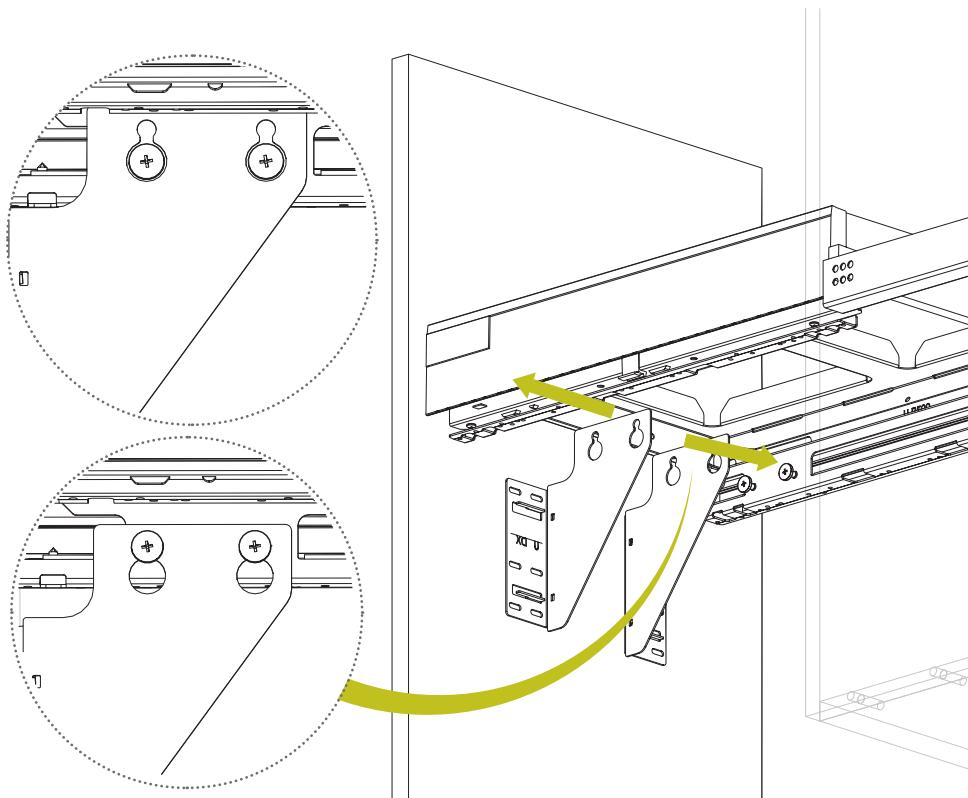
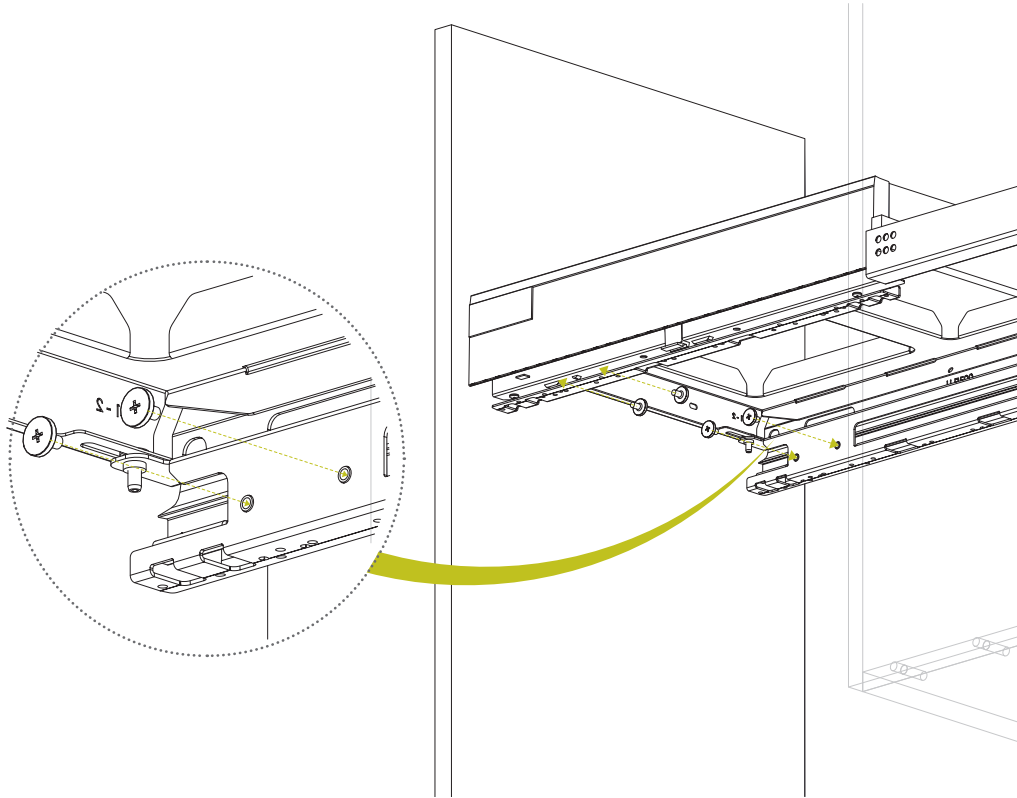

N°6 3,9x13



ES. Cassetto Blum tandembox.
E.G. Blum tandembox drawer.



11

Posizionare gli squadretti stabilizzatori anta C a contatto con l'antina quindi serrare le quattro viti M5x8, in fine fissare gli squadretti stabilizzatori C all' anta con sei viti 3,9x13.
Position the door stabilizing elements C in contact with the door then tighten the four M5x8 screws, finally fix the stabilizing elements C to the door with six 3,9x13 screws.
Mettre les éléments de stabilisation de porte C en contact avec la porte puis serrer les quatre vis M5x8, enfin fixer les éléments de stabilisation de porte C à la porte avec six vis 3,9x13.
Poner los elementos para la estabilización de la puerta C en contacto con la puerta, luego apretar los cuatro tornillos M5x8, finalmente fijar los elementos para la estabilización de la puerta C a la puerta con seis tornillos 3,9x13.

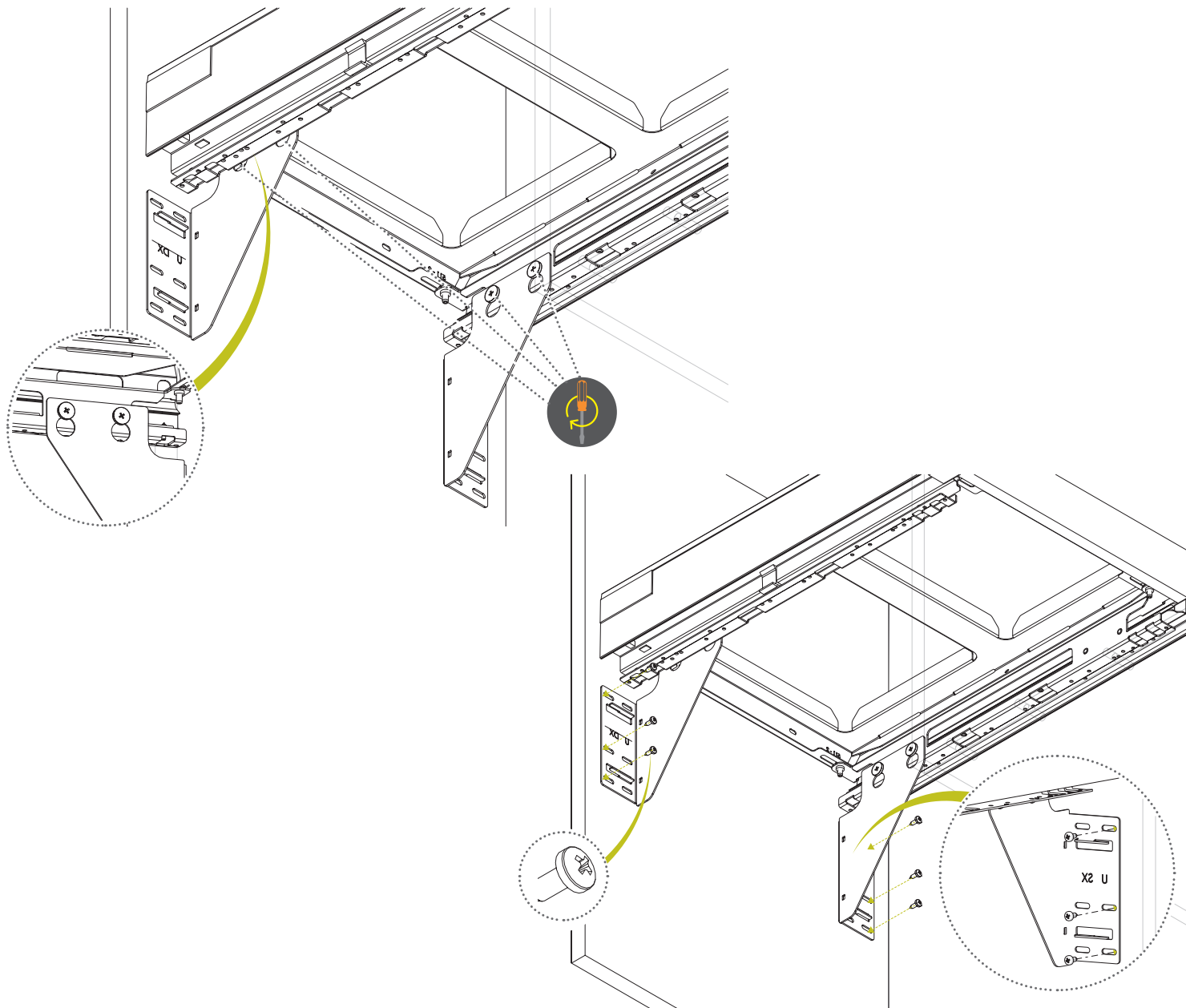

12

Montare i cover D.
Mount the cover D.
Monter les caches D.
Montar las tapas decorativas D.

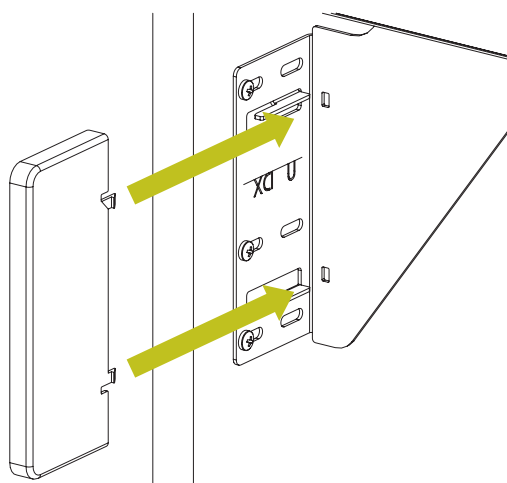

13**N°2 3,9x13**

Se si ha un'anta piena, fissare il telaio A all'anta con le viti 3,9x13 per maggiore rigidezza.

If you have a solid door, fix the frame A to the door with a 3,9x13 screw to increase the stability.

Si vous avez une porte pleine, fixez le cadre A à la porte avec une vis 3,9x13 pour augmenter la stabilité.

Si tiene una puerta sólida, fijar el marco A a la puerta con un tornillo de 3,9x13 para aumentar la estabilidad.

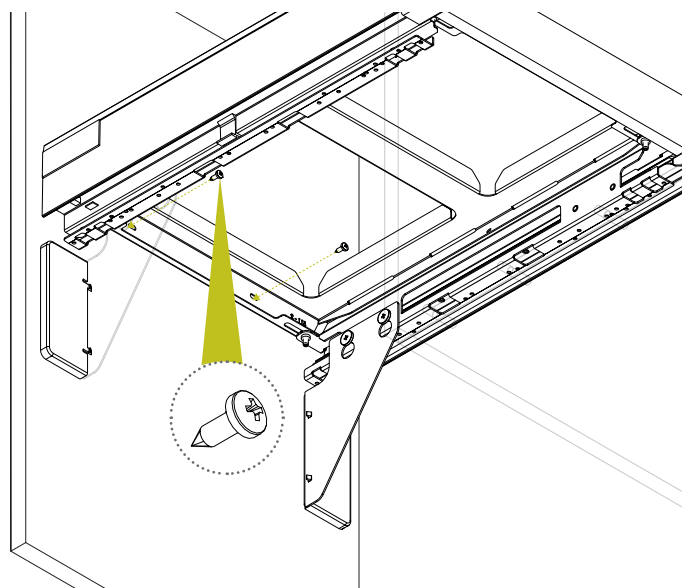
**14**

Applicare il velcro e posizionare i sacchi.

Apply the velcro and place the bags.

Appliquer le velcro et monter les sacs.

Aplicar el velcro e colocar los contenedores.

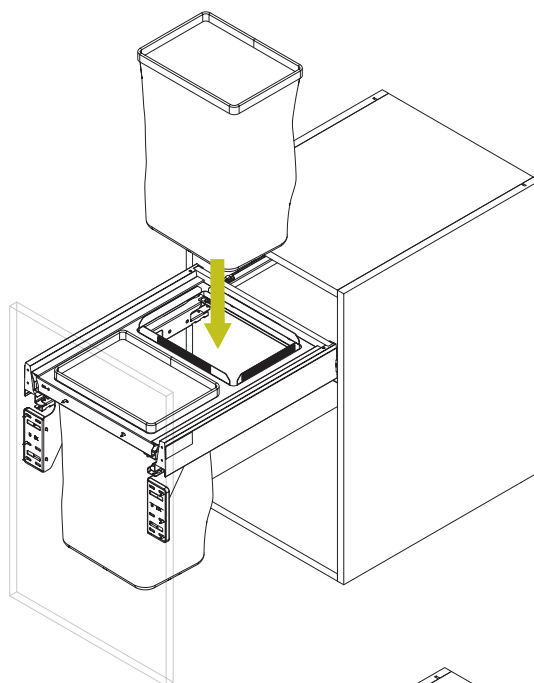
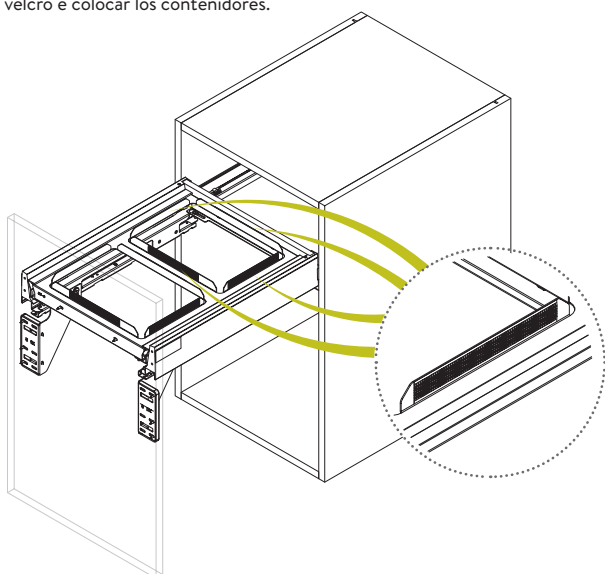
**511U**

Due sacchi
Two bags
Deux sacs
Dos bolsas

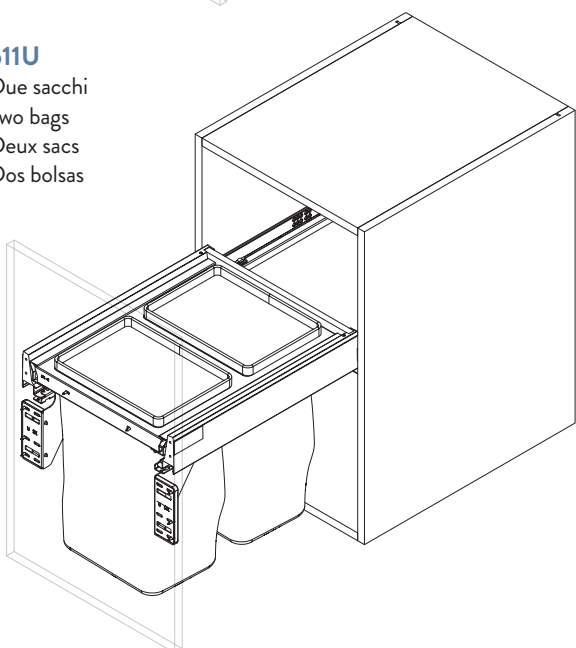
**511U**

Un sacco
One bag
Un sac
Una bolsa

