



ART 295L

SIGE S.P.A.
60020 POLVERIGI (AN) ITALY
TEL +39 071 90 90 000 R.A. - FAX +39 071 90 90 804
WWW.SIGE-SPA.IT INFO@SIGE-SPA.IT

REV 00.2020
FOIST000040

PRODOTTO ED ASSEMBLATO IN ITALIA / MADE AND ASSEMBLED IN ITALY / FABRIQUÉ ET ASSEMBLÉ EN ITALIE / HECHO Y MONTADO EN ITALIA

CARATTERISTICHE • FEATURES • CARACTÉRISTIQUES • CARACTERÍSTICAS

Colonna attrezzata estraibile reversibile a 5/6 cesti.
Pull out equipped and reversible larder with 5/6 baskets.
Colonne équipée extractible et reversible avec 5/6 paniers.
Column aparejada extraíble y reversible con 5/6 cestos.

MINUTERIA INTERNA • FITTINGS • FERRURE • FERRETERIA

N°4 M6x40 Brugola bottone / Button Allen key / Clè Allen bouton / Llave Allen botón
N°2 M5x14 Brugola cilindrica / Cylindrical Allen key / Clè Allen cylindrique / Llave Allen cilíndrica
N°24 4x16 Vite Autofilettante / Self-tapping screw / Vis autotaraudeuse / Tornillo autorroscante

COMPONENTI • PARTS • COMPOSANTS • COMPONENTES

- A. N°1 Telaio / Frame / Chassis / Estructura
- B. N°1 Guida / Slide / Coulisse / Guía
- C. N°1 Guida laterale / Lateral slide / Coulisse latérale / Guía lateral
- D. N°1 Perno di scorrimento / Sliding pin / Pivot de coulissement / Pasador deslizante
- E. N°2 Staffa di trascinamento / Dragging bracket / Patte de traction / Soporte de arrastre
- F. N°10 Gancio cesti in filo 295 295i / Hook for wire baskets 295 295i
Crochet pour paniers en fil 295 295i / Gancho para cestos en alambre 295 295i
- G. N°10 Gancio cesti in piattina 295+ / Hook for flat wire baskets 295+ /
Crochet pour paniers en fil plat 295+ / Gancho para cestos en alambre plano 295+
- H. N°5 Cesto 295+ / Basket 295+ / Panier 295+ / Cesto 295+
- I. N°5 Cesto 295i / Basket 295i / Panier 295i / Cesto 295i
- L. N°5 Cesto 295 / Basket 295 / Panier 295 / Cesto 295
- M. N°2 Set cover staffa di trascinamento / Set cover dragging bracket
Set cover patte de traction / Set cover soporte de arrastre

UTENSILERIA • TOOLS • OUTILS • INSTRUMENTOS



MANUTENZIONE/ MAINTENANCE/ ENTRETIEN/ MANTENIMIENTO

Pulire con un panno morbido ed asciutto. Evitare l'uso di solventi e/o abrasivi.
Clean with a soft, dry cloth. Avoid using solvents or abrasive.
Nettoyez avec un chiffon sec et doux. N'utilisez pas aucun solvant ou produit abrasif.
Limpiar con paño suave y seco. Evitar el uso de solventes y/o abrasivos.

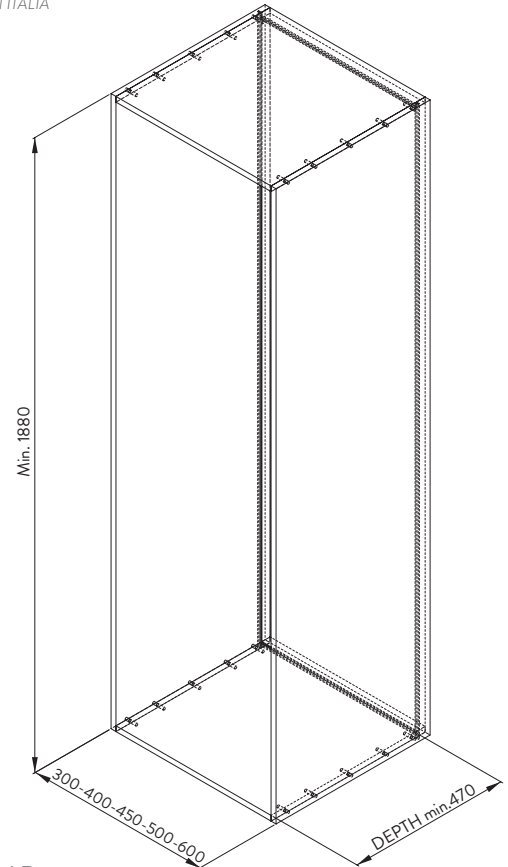

MAX LOAD
CAPACITY 60 KG

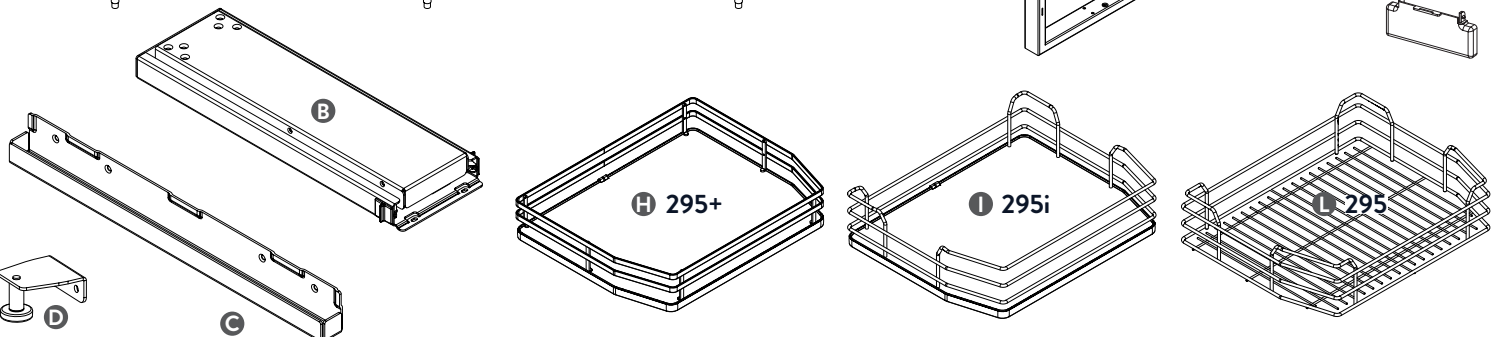
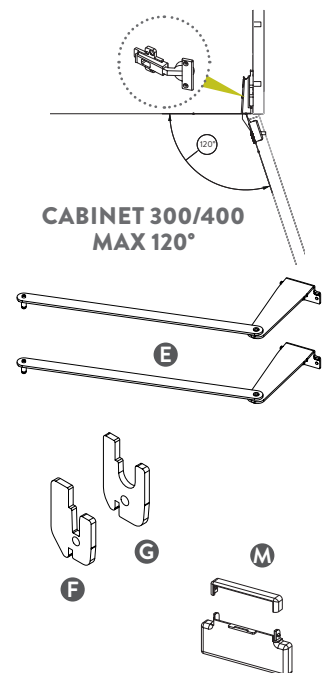
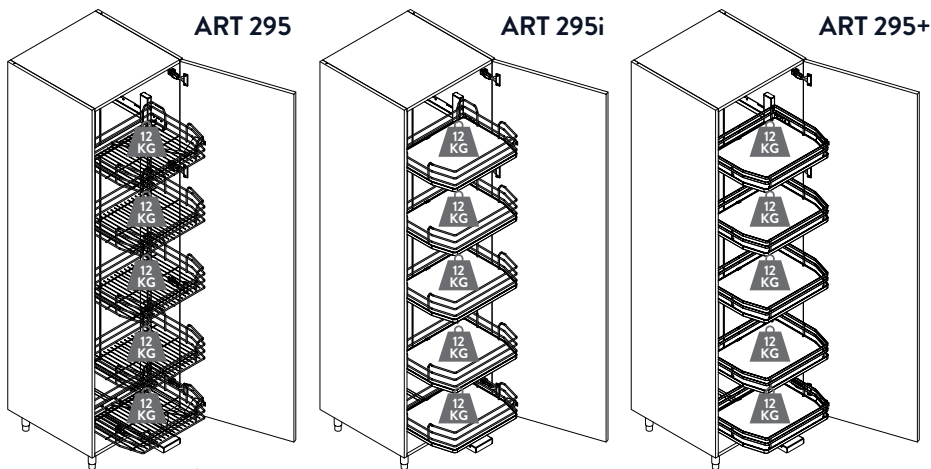

N°2 M5x14



1

Installare un piedino (non fornito) al centro del mobile. Una volta scelto il verso dell'apertura dell'anta, utilizzare le 2 viti M5x14 per avvitare il perno di scorrimento D nel telaio A affinché lo stesso perno si trovi nel lato cerniera.

Place a foot (not supplied) in the centre of the furniture. Choose the door opening direction and then screw the sliding pin D into the frame A by using the two screws M5x14, so that the pin is in the hinge side of the furniture.

Posez un pied (pas muni) au centre du meuble. Choisissez la ouverture de la porte et après vissez le pivot de coulissement D avec les deux vis M5x14, afin que le pivot est dans la côté du meuble où il y a la charnière.

Colocar un pie (no incluido) en el centro del mueble. Elegir la dirección de apertura de la puerta y después atornillar el pasador deslizante D en la estructura A con los dos tornillos M5x14, así que el pasador está en el lado del mueble con la bisagra.

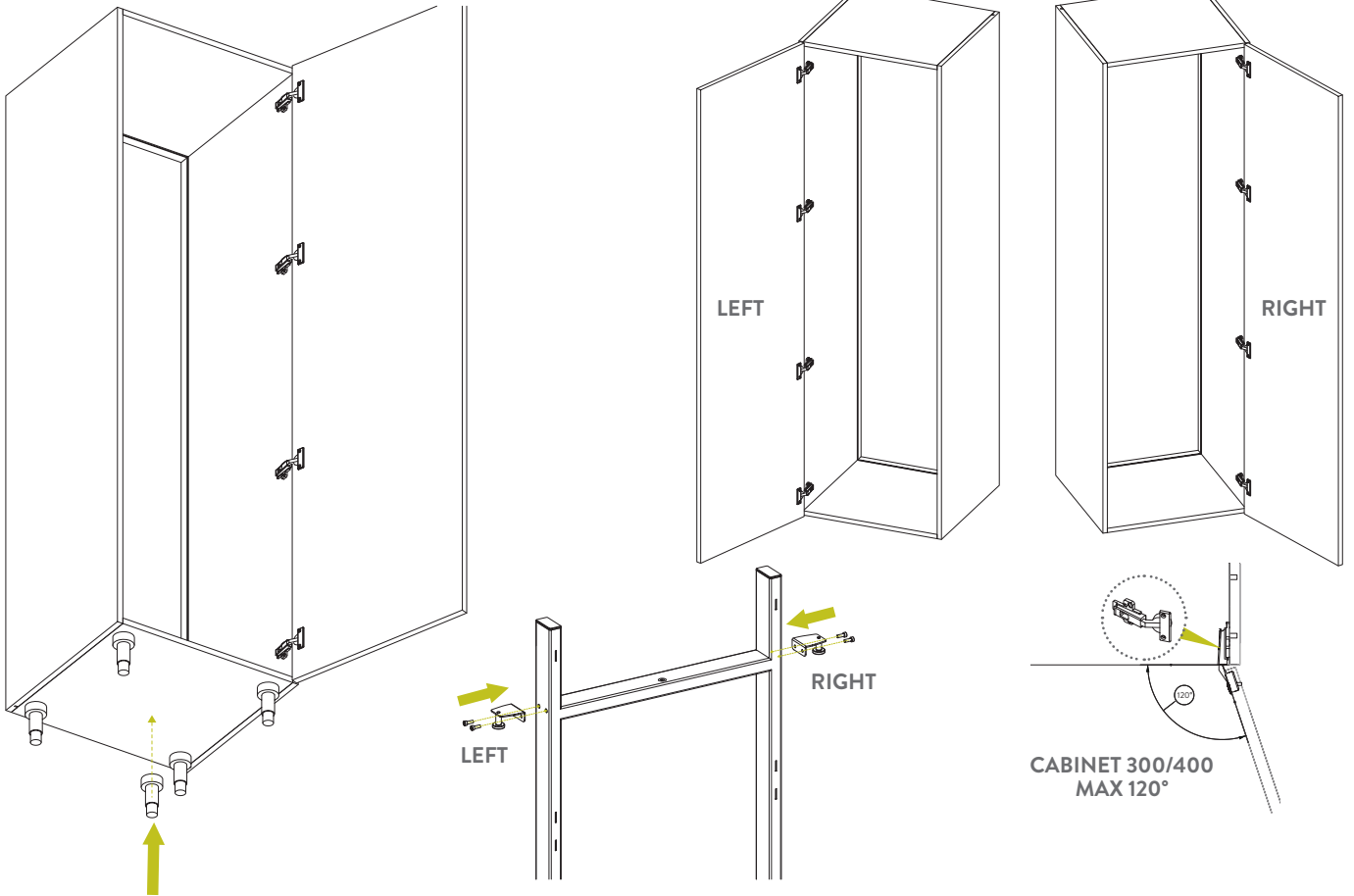

N°4 4x16



2

Installare la guida laterale C sul fianco del mobile, rispettando le quote.
Install the lateral slide C on the side cabinet respecting the quotes.
Installez la coulisse latérale C dans la côté du meuble et respectez les cotes.
Instalar la guía lateral C en el lado del mueble siguiendo las medidas.

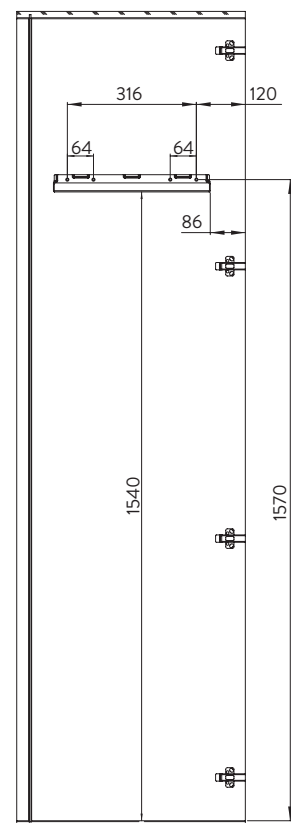
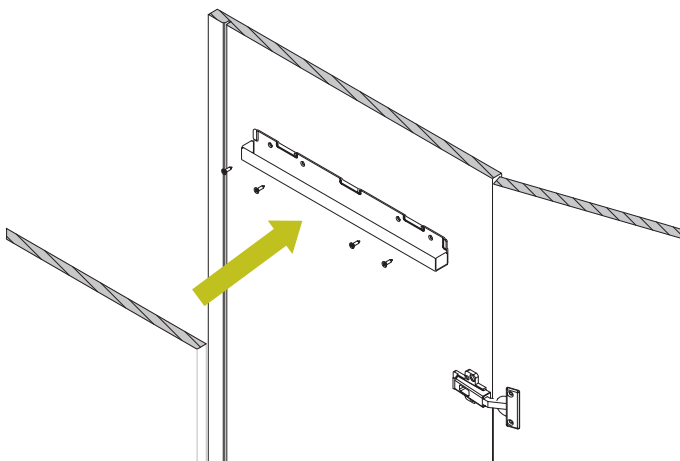

N°6 4x16



3

Installare la guida B sul fondo del mobile rispettando le quote riferite al lato cerniera.

Fix the slide B on the bottom of the furniture respecting the quotes of the hinge side of the furniture.

Fixez la coulisse B sur le fond du meuble et respectez les cotes de côté du meuble où il y a la charnière.

Arreglar la guía B al fondo del mueble siguiendo las medidas del lado del mueble donde está la bisagra.

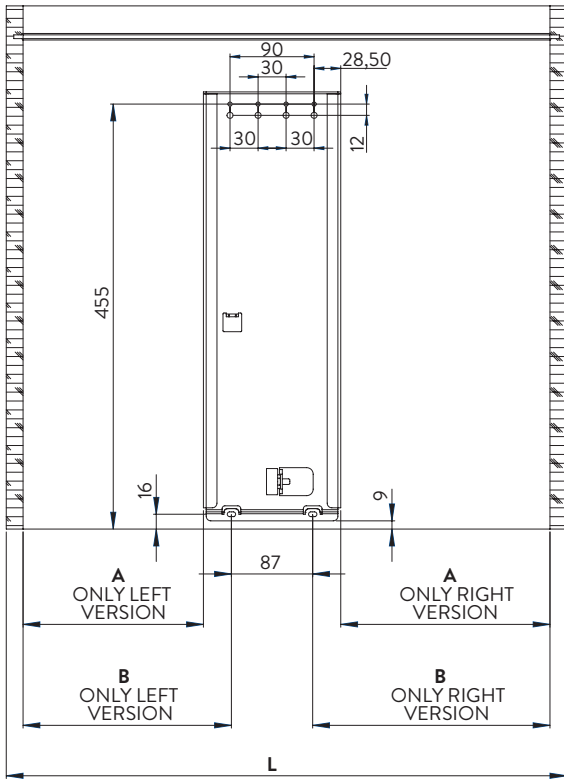

L	A	B
300	70	100
400	120	150
450	149	179
500	174	204
600	224	254

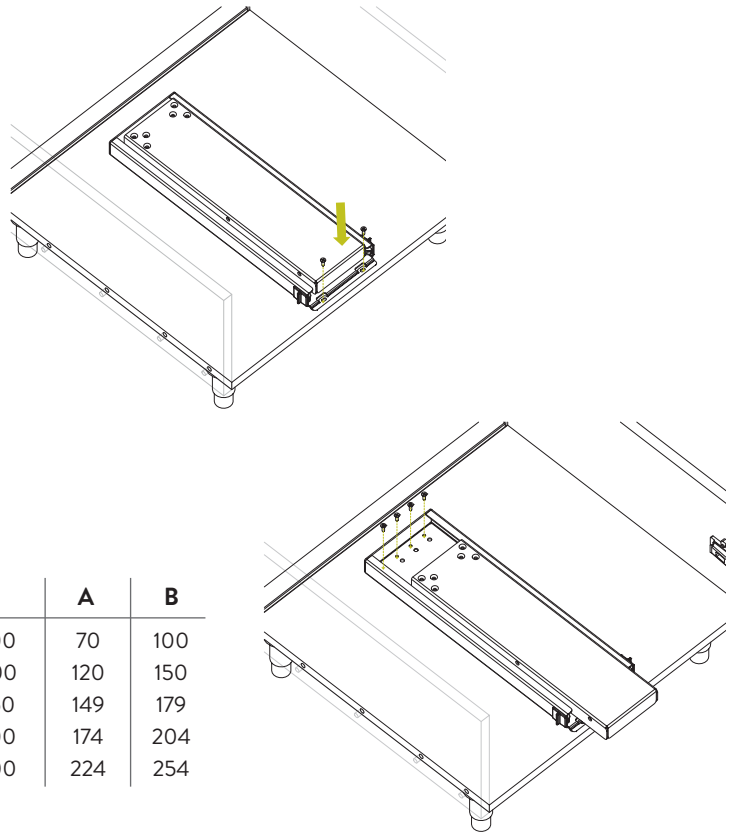

N°4 M6x40



4

Inserire il Telaio A e fissarlo tramite 4viti M6x40 (vedi immagine).

Insert the frame A and fix it by using the four screws M6x40, as per related picture.

Insérez le chassis A et fixez-le avec les quatre vis M6x40, comme dans la photo.

Insertar la estructura A y fijarla con los cuatros tornillos M6x40, como indicado en la imagen.

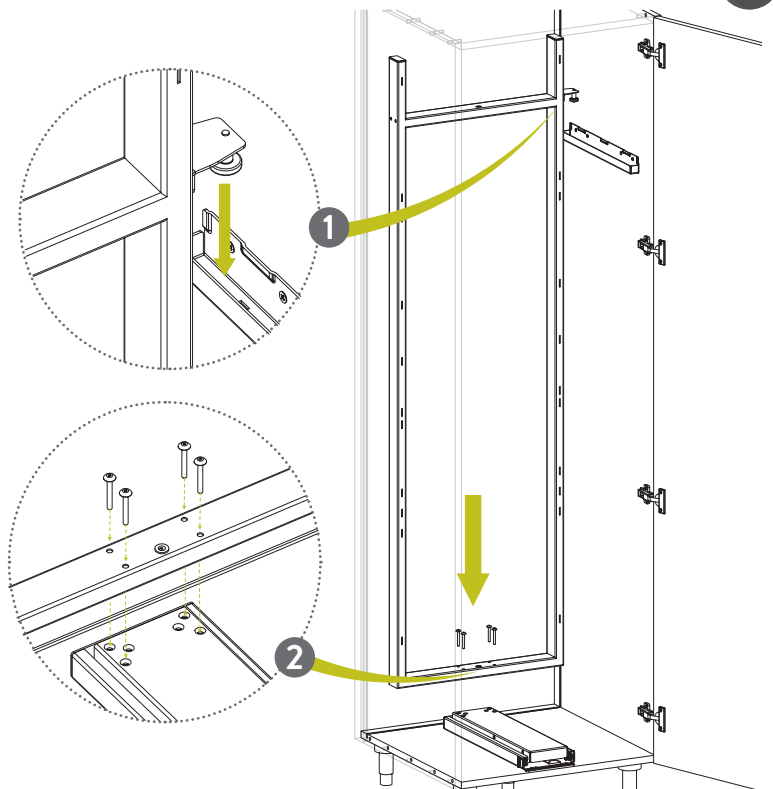



Montare le staffe di trascinamento E sull'anta rispettando le quote ed inserirle nel telaio A e montare i cover M, come mostrato nelle immagini.

Installez les crochets E sur la porte en respectant les guillemets et insérer dans le cadre A et les capots M, comme indiqué sur les images.

Install the dragging brackets E on the door respecting the quotes and insert them into the frame A and the covers M, as shown in the pictures.

Instale los soportes de arrastre E en la puerta respetando las comillas e inserte Colóquelos en el marco A y las cubiertas M, como se muestra en las imágenes.

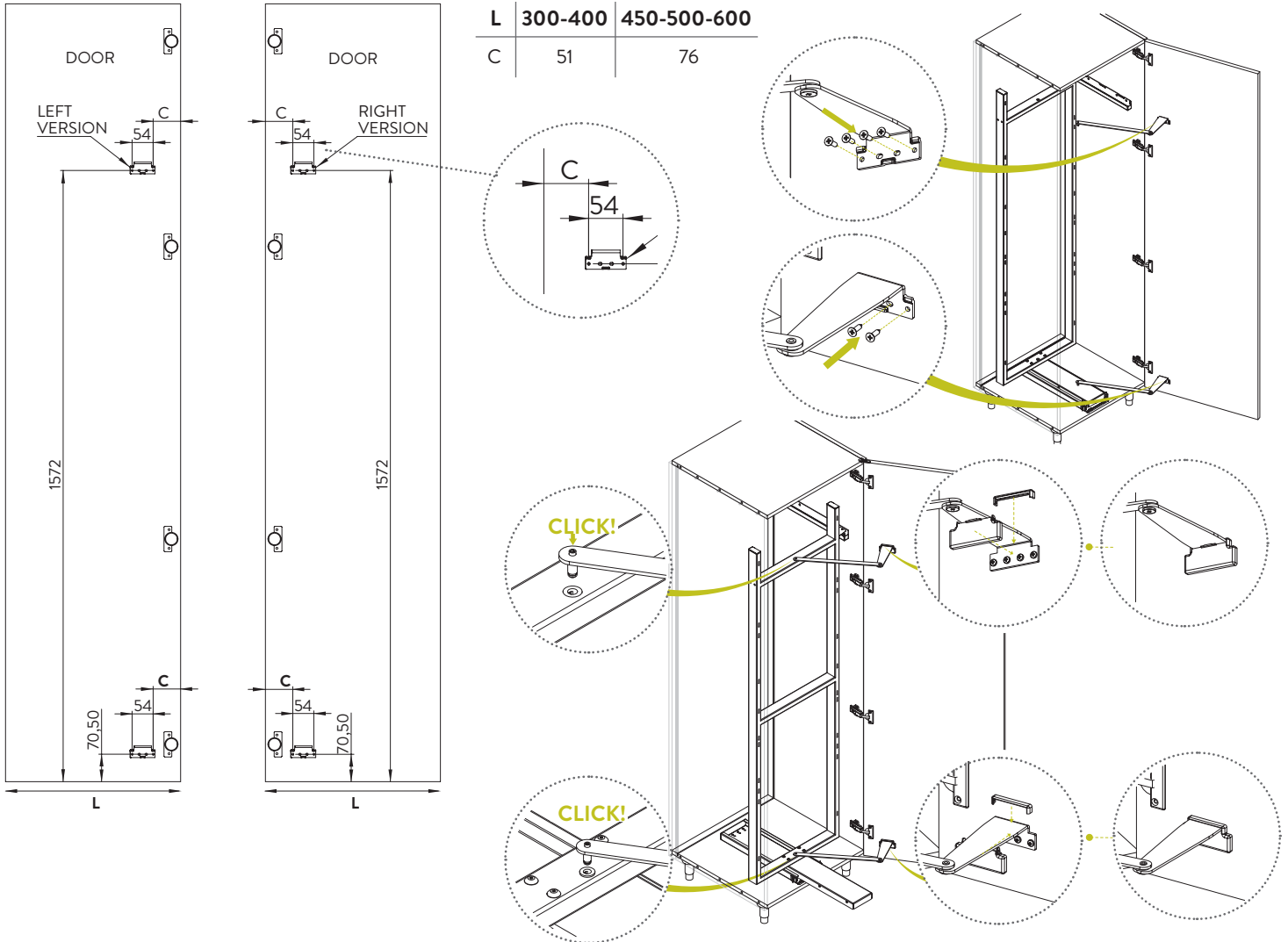

Inserire i ganci in dotazione F o G come illustrato. Infine agganciare i cestì. As indicated, put the hooks F or G and finally hang the baskets.

Insérez les crochets F ou G comme présenté et enfin accrochez les paniers. Poner los ganchos F o G como indicado y por ultimo colgar los cestos.

