



ART E240

REV 00.2024
FOIST00468

PRODOTTO ED ASSEMBLATO IN ITALIA / MADE AND ASSEMBLED IN ITALY / FABRIQUÉ ET ASSEMBLÉ EN ITALIE / HECHO Y MONTADO EN ITALIA

CARATTERISTICHE • FEATURES • CARACTÉRISTIQUES • CARACTERÍSTICAS

Porta scarpe per telaio estraibile.
Shoe holder for removable frame.
Range-chaussures pour cadre amovible.
Zapatero para estructura extraíble.

MINUTERIA INTERNA • FITTINGS • FERRURE • FERRETERIA

N°12 M4x20 (DEPTH.480)

N°6 M4x20 (DEPTH.400)

COMPONENTI • PARTS • COMPOSANTS • COMPONENTES

A. N°1 Kit fianchi in lamiera/ Sheet metal side kit/ Kit latéral tôle/ Kit lateral de chapa/
B1. DEPTH 480 N°6 Tubi in alluminio/ Aluminum tubes/ Tubes en aluminium/Tubos de aluminio
B2. DEPTH 400 N°3 Tubi in alluminio/ Aluminum tubes/ Tubes en aluminium/Tubos de aluminio
C1. DEPTH 480 N°12 Tappi/ Caps/ Casquettes/ Tapas
C2. DEPTH 400 N°6Tappi/ Caps/ Casquettes/ Tapas

MANUTENZIONE • MAINTENANCE • ENTRETIEN • MANTENIMIENTO

Pulire con un panno morbido ed asciutto. Evitare l'uso di solventi e/o abrasivi.
Clean with a soft, dry cloth. Avoid using solvents or abrasive.
Nettoyez avec un chiffon sec et doux. N'utilisez pas aucun solvant ou produit abrasif.
Limpiar con paño suave y seco. Evitar el uso de solventes y/o abrasivos.

1

Tagliare i tubi alla giusta misura seguendo le indicazioni.
Cut the tubes to the right size following the instructions.
Coupez les tubes à la bonne taille en suivant les instructions.
Corta los tubos al tamaño correcto siguiendo las instrucciones.

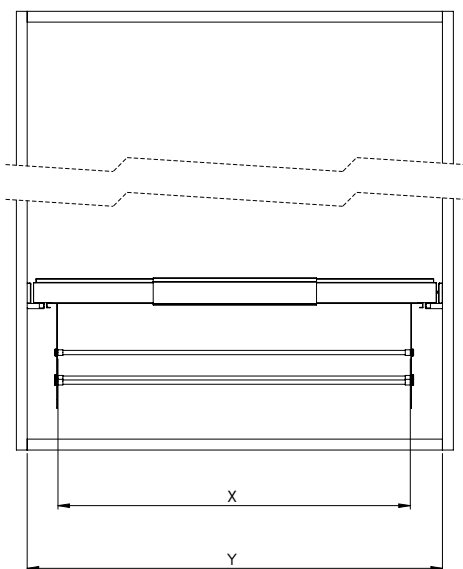

WITHOUT SPACER: X=Y-76mm
WITH ONE SPACER: X=Y-101mm
WITH TWO SPACER: X=Y-126mm

N°12 M4x20 (DEPTH.480) N°6 M4x20 (DEPTH.400)

2

Inserire i tappi (C) in tutti i tubi ed avvitare le viti.
Insert the caps (C) into all the tubes and tighten the screws.
Insérez les bouchons (C) dans tous les tubes et serrez les vis.
Inserte las tapas (C) en todos los tubos y apriete los tornillos.

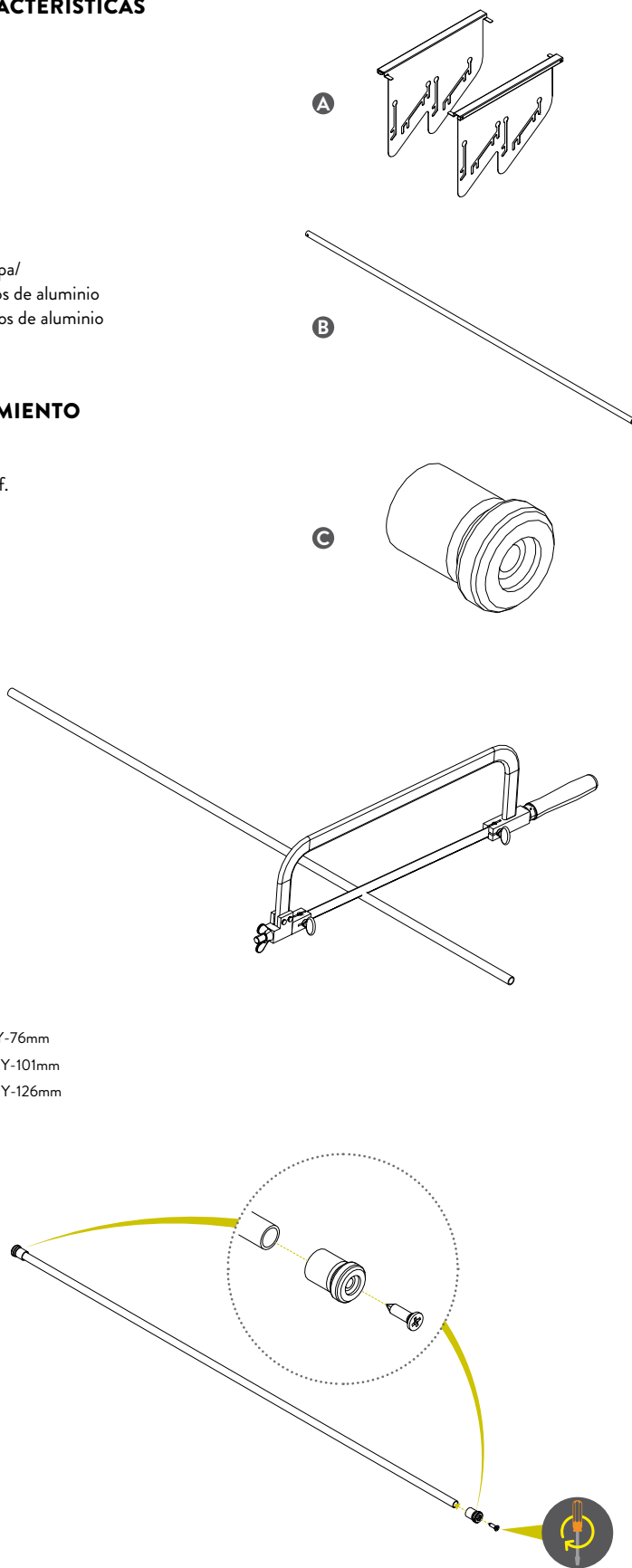

3

Appoggiare i due fianchi in lamiera (A) all'interno del telaio.
 Place the two sheet metal sides (A) inside the frame.
 Placez les deux côtés en tôle (A) à l'intérieur du cadre.
 Coloque los dos lados de chapa (A) dentro del marco.

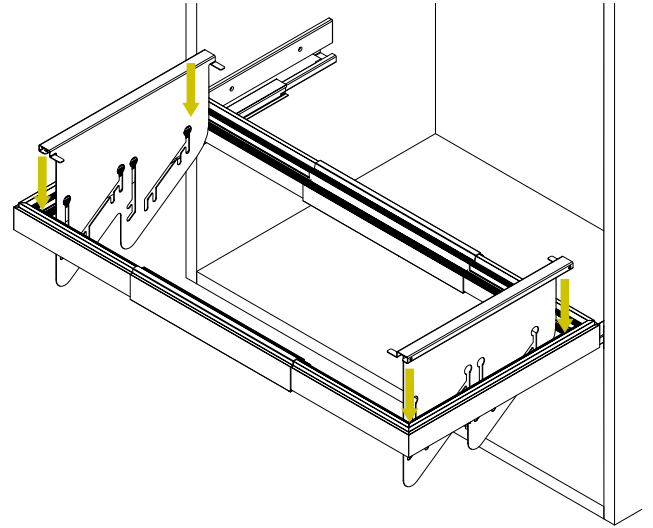
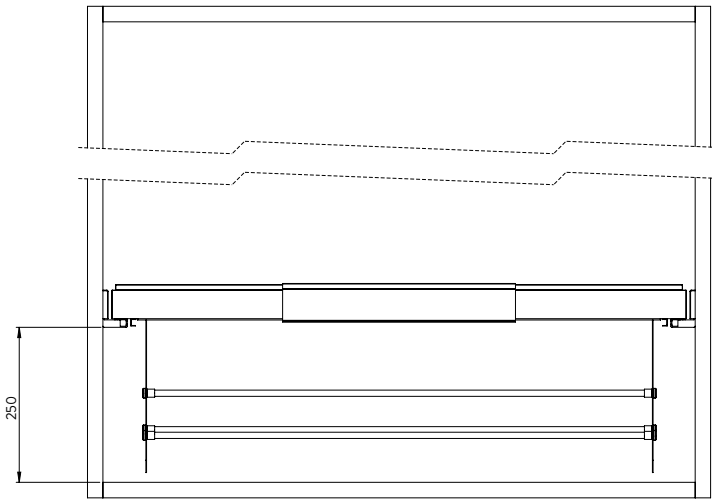
**4**

Inserire i tubi in entrambe le lamiera.
 Insert the tubes into both sheets.
 Insérez les tubes dans les deux feuilles.
 Inserte los tubos en ambas hojas.

